

4

3

2

1

REVISIONS				
ZONE	REV	DESCRIPTION	DATE	APPROVED

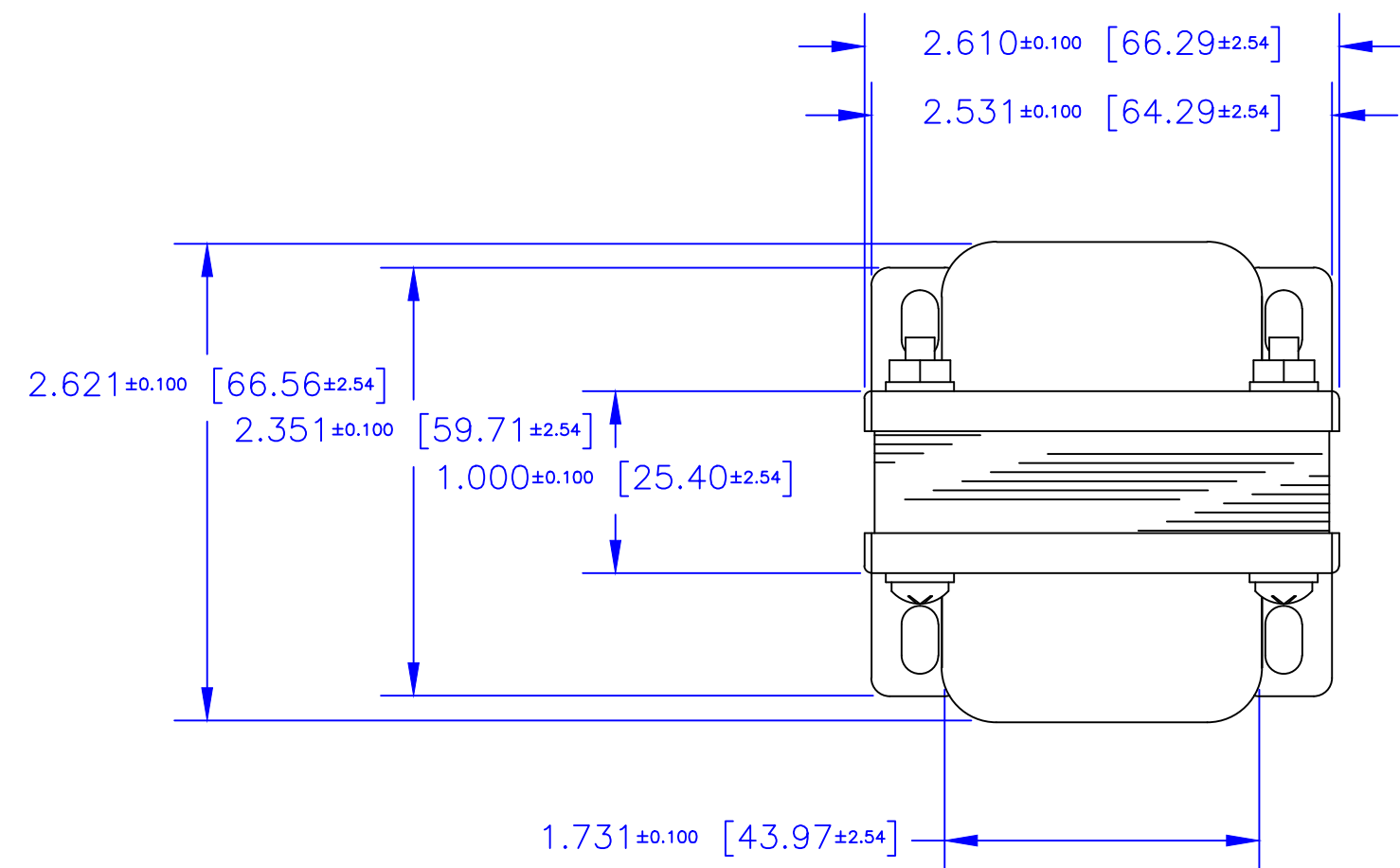

SUGGESTED MOUNTING HOLES

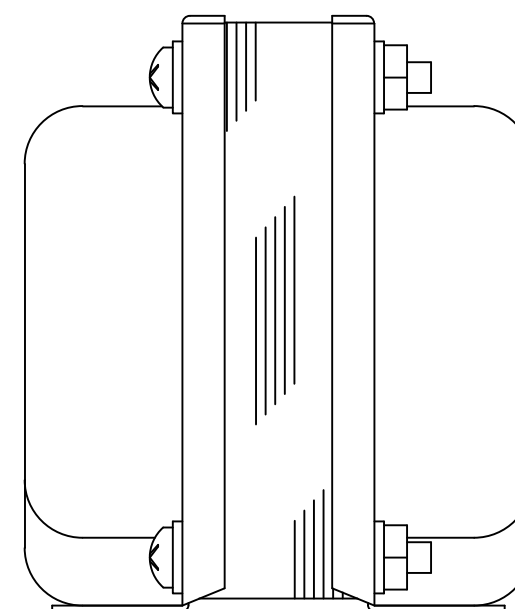
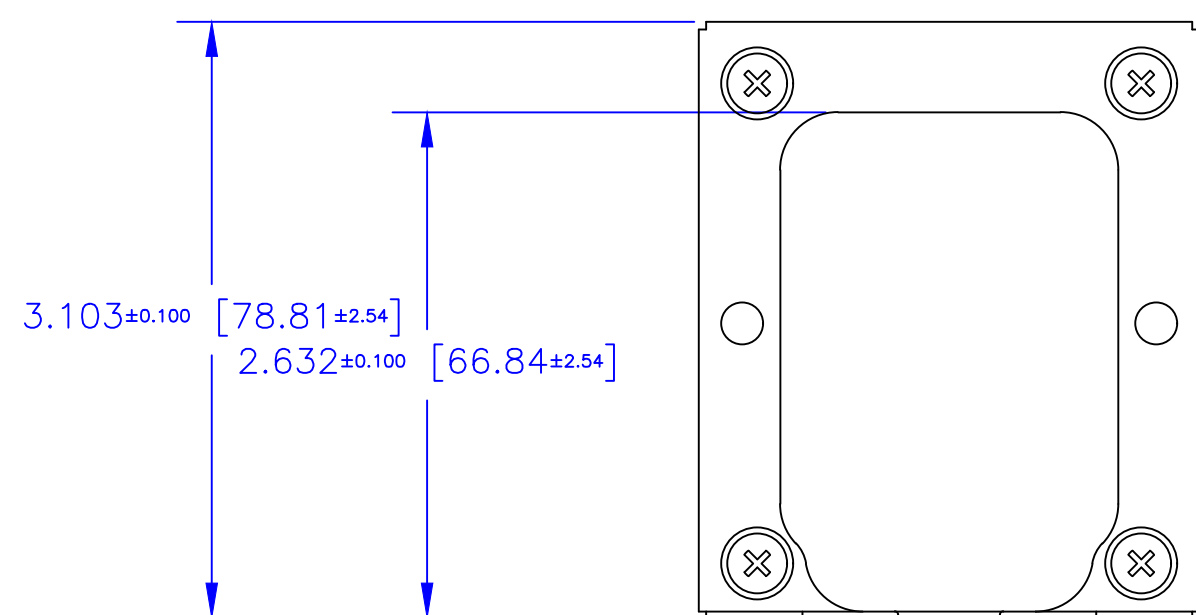
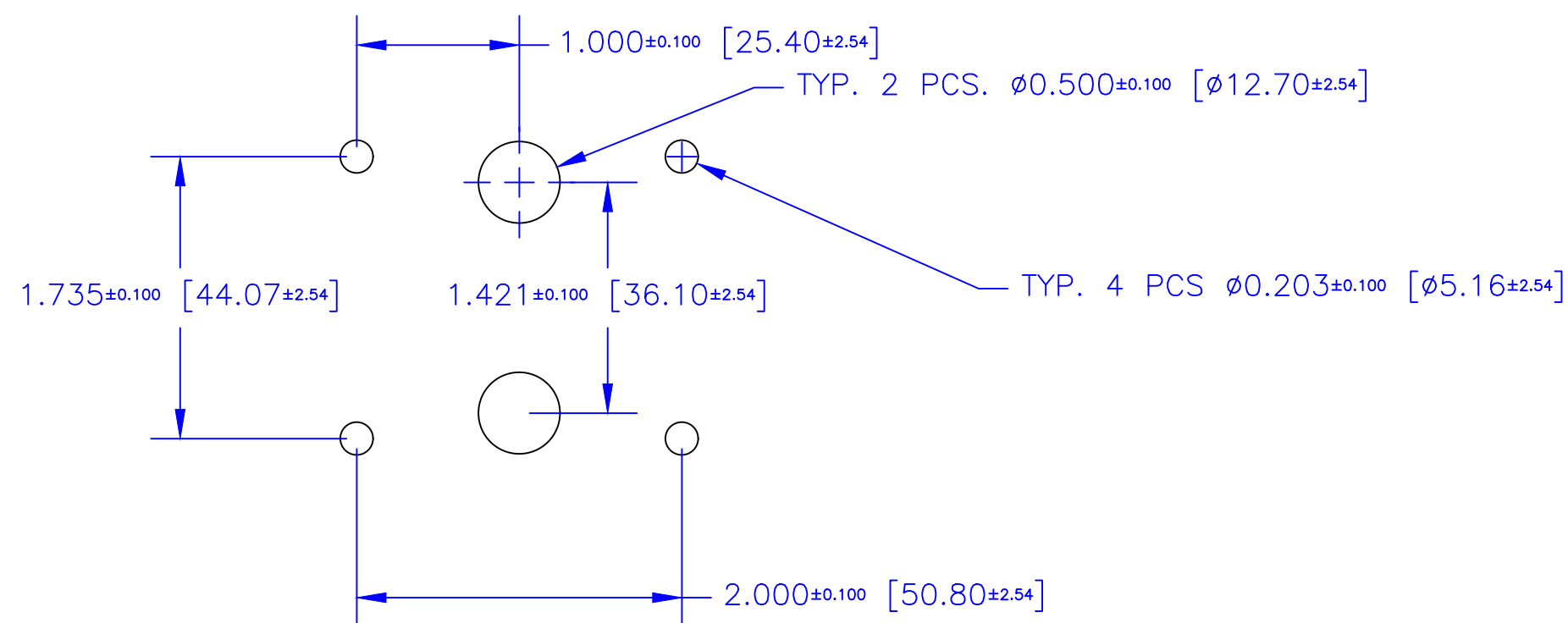

**NOTES: UNLESS OTHERWISE SPECIFIED!

- All material is UL listed.
- All material are to be RoHS compliant.
- Bobbin: Nylon 6/6 30% glass filled, Class B, Flammability 94HB UL E184262.
- Magnet Wire: Class B, UL E32638, Gauge depending on the transformer design specifications requirement.
- Finish Tape: Polyester film tape, Class 130°, dielectric strength 5000 volts, UL E17385, guide OANZ2.
- Core Material: Depending on the transformer design specifications requirement.
- Termination: Depending on the transformer design specifications requirement.
- Mounting: Powder coated steel vertical end bells.
- Finish: Styrenated alkyd electrical varnish, air cured, UL E63933.

DRAWING BY Brian Weston		Date 3/2007	EDCOR Electronics	
CHECKED BY Brian Weston		Date 3/2007	7130 National Parks Highway, Carlsbad, NM 88220 Voice: (575) 887-6790 www.edcorusa.com	
APPROVED BY Larry Weston		Date 3/2007	E1100 x 1" vertical end bell mounted	
SIZE C	FSCM NO.	DWG NO. 15000-EI100-100-0X	REV	
SCALE: 1:1		©2015 EDCOR Electronics	SHEET: 1 of 1	

4

3

2

1